

SM-621 Fingerprint Verification Module User Manual

(V1.0)



Miaxis Biometrics Co., Ltd.

January 24, 2007

Preface

Thank you for purchasing SM-621 Fingerprint Verification Module (hereinafter referred to as Module) developed by Maxis Biometrics Co., Ltd. (hereinafter referred to as Maxis).

This User's Manual, aimed at software and hardware application engineers, including contents of Module functions, hardware and software interfaces, etc.

To ensure smooth application, users are expected to read this manual carefully. Besides having an understanding of technical concepts and use instructions mentioned in this manual, readers ought to read carefully chapters related to pin definitions, time and sequences as well as notes.

Please keep this user manual for reference.

-
- I Maxis has always put strenuous product improvement as the guideline. Thus, this manual is subject to changes without notices. Please visit our website (www.miaxis.com) or call us to obtain updated information.**
 - I We are trying our best to ensure accuracy of this manual. However, for any questions or errors you may encounter, please contact Maxis directly or go to our authorized distribution agents. We will be grateful to receive any suggestions from you.**
 - I Without written authorization from Maxis, any act of copying or adaptation to this manual will be regarded as severe violation of Maxis' intellectual property rights.**
-

Miaxis, Miaxis Logo as well as JusTouch are trademaeks of Maxis Biometrics Co., Ltd. All other brands or products may be trademarks, service marks or registered marks of their respective owners. All information referred to in this manual is owned by Maxis Biometrics Co., Ltd. Copying is strictly forbidden without written authorization from Maxis Biometrics Co., Ltd. All copy rights reserved.

Table of Content

<i>I System Description</i>	5
1.1 System Feature	5
1.2 Application	6
1.3 Related Terms Regarding Fingerprint Verification System	6
<i>II Specification & Interface</i>	7
2.1 Technical Parameter	7
2.2 Sensor Dimension	7
2.3 External Interface	8
<i>III Communication Protocol</i>	9
3.1 Protocol Packet Type & Format	9
3.2 Code & Decode	10
3.2.1 Coding Rules	10
3.2.2 Decoding Rules.....	10
3.2.3 Coding Examples.....	11
3.3 Command Control Flowchart	11
3.3.1 Template Enrollment.....	11
3.3.2 Upload Template.....	12
3.3.3 Fingerprint Verification	13
<i>IV Module Command</i>	14
4.1 Command Set	14
4.2 Confirm Code Definition	15
4.3 Command in Detail	16
4.3.1 Detect Finger	16
4.3.2. Enroll Image	17
4.3.3 Generate Minutiae.....	18
4.3.4 Move Minutiae Files	19
4.3.5 Accurate Verification of Two Fingerprint Minutiae	19
4.3.6 Search Fingerprint.....	20
4.3.7 Merge Minutiae (Generate Template)	21
4.3.8 Store Template.....	21
4.3.9 Read Template	22
4.3.10 Upload Minutiae or Template	23
4.3.11 Download Minutiae or Template.....	24
4.3.12. Upload Image	24
4.3.13 Download Image.....	25
4.3.14 Delete a Template.....	26

4.3.15 Empty Fingerprint Database	26
4.3.16 Read System Parameter List.....	27
4.3.17 Set Security Level	28
4.3.18 Set Password.....	29
4.3.19 Verify Password	29
4.3.20 System Reset	30
4.3.21 Light Flash Indication	31
4.3.22 Write Notepad.....	32
4.3.23 Read Notepad	33
4.3.24 Level Search Fingerprint Database	33
4.3.25 Check Fingerprint Database	34
<i>Attachment I Methods to Lower FRR</i>	36

I System Description

1.1 System Feature

SM-621 backlight fingerprint verification module is the latest product introduced by Miaxis Biometrics Co., Ltd. in 2007.

SM-621 module series adopt optic fingerprint sensor, which consists of high-performance DSP processor and chips such as Flash, etc. SM-621 is able to conduct fingerprint image processing, template generation, template matching, fingerprint searching, template storage, etc. Compared with similar products from other suppliers, SM-621 proudly boasts of following features:

n Proprietary Intellectual Property

Optic fingerprint enrollment device, SM-621 hardware as well as fingerprint algorithm are all developed by Miaxis.

n Wide Application Range of Fingerprints

Self-adaptive parameter adjustment mechanism is used in the course of fingerprint enrollment. This ensures good image quality for even dry or wet fingers, thus it has a wider application range.

n Low Price

The cost of module is greatly reduced by using self-developed optic fingerprint enrollment device.

n Excellent Algorithm

SM-621 algorithm is specially written according to optic imaging theory. The algorithm is good for de-shaped or low-quality fingers due to its excellent correction and tolerance features.

n Easy to Use and Expand

It is not necessary for user to have professional knowledge in the field of fingerprint verification. User can develop powerful fingerprint verification application systems with the command set provided by SM-621.

n Low Power Consumption

Sleep/awake control interface makes SM-621 suitable for occasions that require low power consumption.

n Different Security Levels

User can set different security level according to different application environment.

1.2 Application

SM-621 can be widely used on all low or high level fingerprint verification systems, such as

- n Ordinary safety cabinet, door lock;
- n Complicated access control system;
- n Fingerprint IC card Identification Terminal;
- n Fingerprint identification and verification system associated with PC.

Developer can develop various fingerprint verification application systems based on the technical data stated in this manual. (Miaxis also provides SDK based on both PC and MCU51 to facilitate users for secondary development. Please contact Miaxis for further detail)

1.3 Related Terms Regarding Fingerprint Verification System

I Fingerprint Minutiae:

Minutiae extracted by fingerprint algorithm, which represents all information related to fingerprint. Operations such as fingerprint storage, verification, searching, ect. are all realized through fingerprint minutiae.

I 1:1 Verification:

To verify two fingerprint minutiae and send back results: verified or unverified.

I 1:N Searching:

Find out the fingerprint minutiae that matches with the designated fingerprint minutiae, and send back results: matching minutiae found or not found. In the former case, the ID of the right fingerprint minutiae will also be sent back.

II Specification & Interface

2.1 Technical Parameter

No.	Item	Parameter	Test Condition
1	System Power Supply	3.6V-7V	
2	Working Current	< 100mA	
3	Peak Current	< 120mA	5V
4	Fingerprint Image Enrollment Time	< 250ms	5V
5	1:1 Verification Time	< 600ms	Minutiae extraction + Fingerprint Verification
6	1:240 searching Time	< 2s	
7	Fingerprint Storage Capacity*	240/752/1776	
8	FAR	< 0.001 %	
9	FRR	< 1.5 %	
10	External Interface	UART**	
11	Module Dimension	56.0×38.5×8.5mm	
12	Sensor Dimension	31×21×4.5mm	
13	Fingerprint Template Size	256 bytes	

*Template Storage Capacity is classified as three levels: 240, 752 & 1776.

**Baud rate 57600bps

2.2 Sensor Dimension

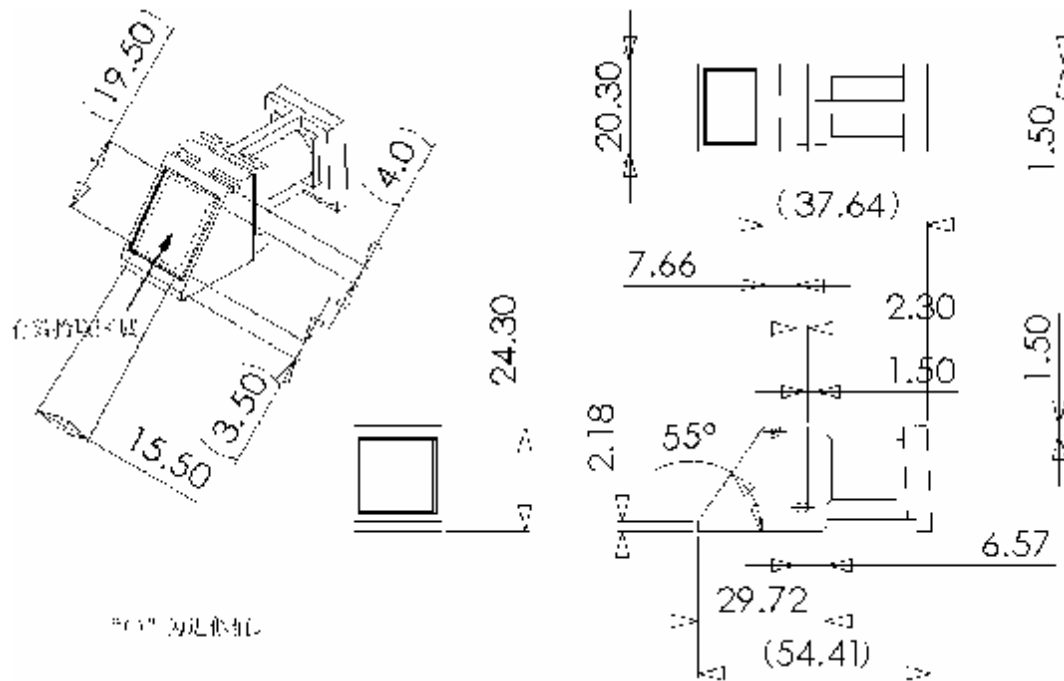

有效拾取区域: available fingerprint image enrollment area.
 “()” 为近似值, “()” is the approx data

2.3 External Interface

The external is a 6-pin single row socket, structured as per below:

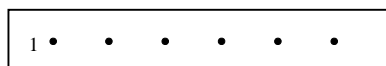

Definition for each pin is as follows:

PIN	NAME	DEFINITION	TYPE	Function
1	VIN	Power supply	P	DC: 3.6V-7V
2	TD	Data Transmission	O	OC output; HOST shall be connected to pull-up impedance
3	RD	Data Receive	I	TTL Level (3.3V or 5V)
4	NC	Undefined	--	--
5	EN	ABLE Control	I	When in suspense or pull-up impedance, Module works normally. When connecting to Ground, inner power supply is cut off and Module does not work.
6	GND	Power Supply & Ground	P	Power supply & Ground

Note: TD connects to HOST RXD; RD connects to HOST TXD
 Note: 1 pin with CN1 sign

III Communication Protocol

3.1 Protocol Packet Type & Format

HOST sends commands to realize various module functions. Module communications with HOST, such as receiving & sending command/data/structure, are completed in the form of protocol packet. Regarding the content of the packets, protocol packet is classified into the following 3 types:

Command Packet

1 byte	4 bytes	2 bytes	1 byte				2 bytes
Packet Flag01	Equipment Address Code	Packet Length	Command	Parameter 1	Parameter 2	...	Parameter n	Check Sum

Data Packet

1 byte	4 bytes	2 bytes	128 bytes...	2 bytes
Packet Flag02	Equipment Address Code	Packet Length	Data	Check Sum

Note: In most cases, a single data packet not to be transmitted; usually it is a batch data (consisting of multiple data packets) transmission process.

End Packet

1 byte	4 bytes	2 bytes	N bytes...	2 bytes
Packet Flag08	Equipment Address Code	Packet Length	Data	Check Sum

Note: End Packet is a special data packet. It is the last of the multiple data packets to be transmitted in the batch data transmission.

3.2 Code & Decode

All packets must be coded before transmission. The corresponding recipient will obtain the protocol packet with accurate information only after decoding.

3.2.1 Coding Rules

1. Data packet uses 0xC0 as start and end character.
2. If there is 0xC0 in the packet, then replace it with 0xDB and 0xDC.
3. If there is 0xDB, add 0xDD after it.
4. Data packet cannot enter execution flowchart independently. It must follow Command Packet or Response Packet. Packet Length is the bytes of packet content (Command, Parameter or Data) .

3.2.2 Decoding Rules

1. The 0xC0 character received by the recipient is regarded as Phase Border mark.
2. If 0xDB is received with 0xDC following, then replace it with 0xC0.
3. If 0xDB is received with n 0xDD, then delete one 0xDD.

4. Check Sum is the sum of all bytes from Packet Flag to Check Sum (before encoding).
Disregard those values that exceed 2 bytes.

3.2.3 Coding Examples

● Encode finger detection command packet

Phase	1 byte	4 bytes	2 bytes	1 byte	2 bytes	Phase
Border	Packet	Module	Packet	Command	Check Sum	Border
Mark	Flag	Address	Length	Code		Mark
	01H	00H x 4	00H 01H	01H	00H 03H	
C0H	01H	00Hx4	00H 01H	01H	00H 03H	C0H

● Encode data packet

Phase	Packet	Equipment	Packet		Check	Phase
Border	Flag	Address	Length	Data (N)	Sum	Border
Mark	1 byte	4 bytes	2 bytes	N bytes...	2 bytes	Mark
	02H	00H x 4	00H 80H	...C0H...DBH...	01H20H	
C0H	02H	00H x 4	00H 80H	...DBH DCH...DBH DDH...	01H20H	C0H

3.3 Command Control Flowchart

HOST or PC uses combined instructions to control SM-621 module to perform various tasks. This section provides some task instruction flowchart for user's reference.

3.3.1 Template Enrollment

Press finger twice to enroll a fingerprint template and store to flash fingerprint database.

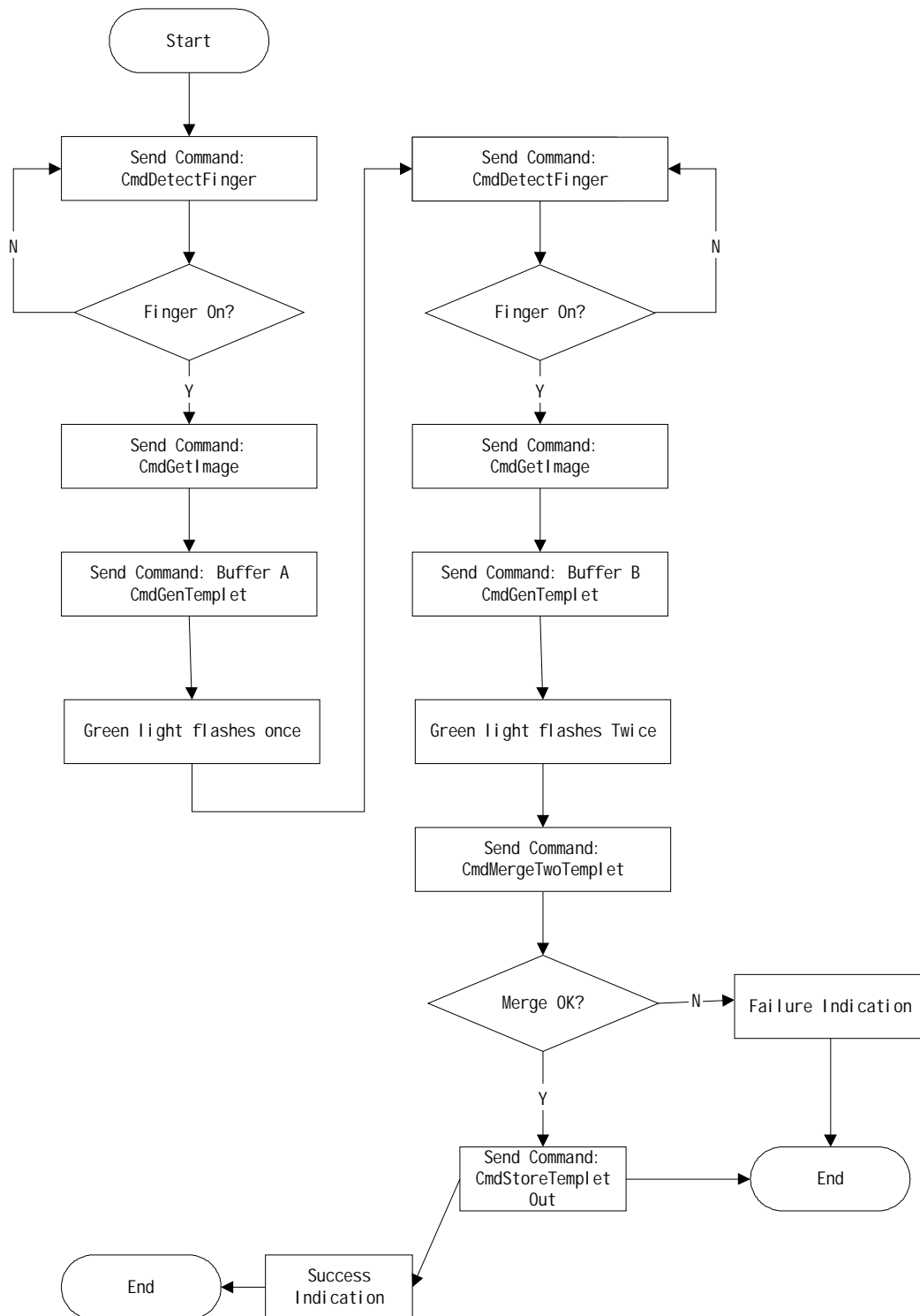

3.3.2 Upload Template

Read a designated template from fingerprint database and upload.

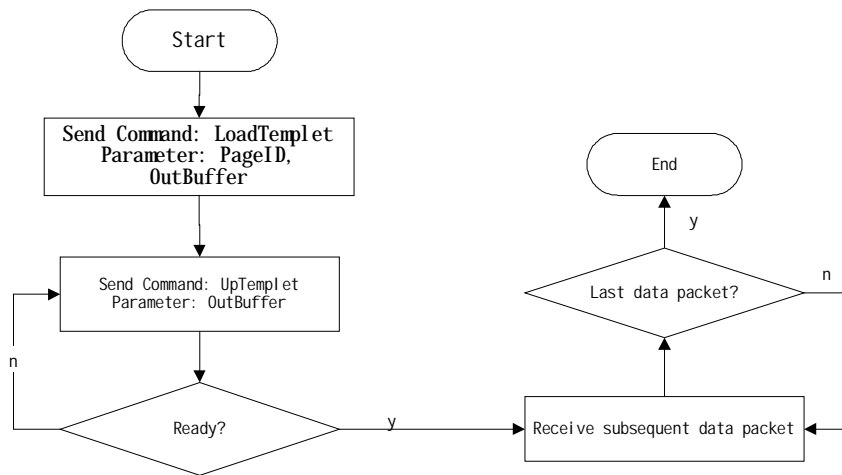

3.3.3 Fingerprint Verification

Read the current fingerprint on the sensor and search in the fingerprint database ranging from 10-100.

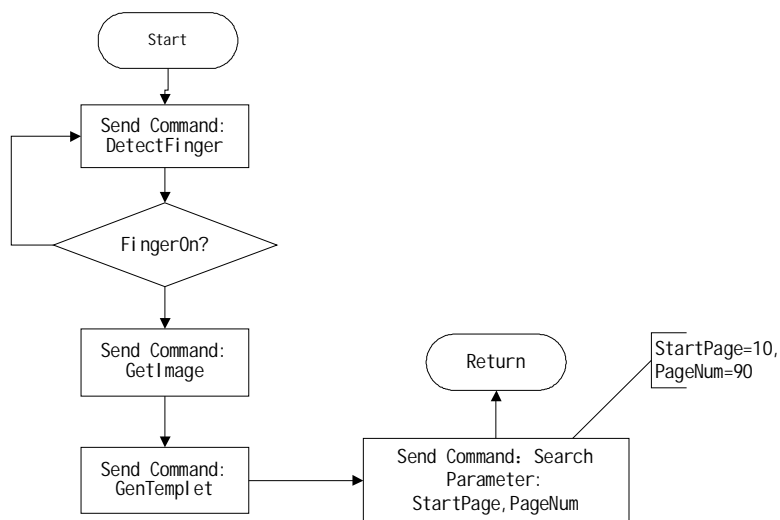

IV Module Command

4.1 Command Set

NO.	Command & Code		Function
1	DetectFinger	01H	Detect finger on sensor
2	GetImage	02H	Get image from sensor
3	GenTemplet	03H	Generate fingerprint minutiae from images
4	MoveTemplet	20H	Move characteristic file among three buffers
5	MatchTwoTemplet	04H	Accurate verification for characteristic files in CharBufferA and CharBufferB
6	Search	05H	Search part of or the whole fingerprint database based on minutiae files in CharBufferA or CharBufferB
7	MergeTwoTemplet	06H	Merge the files in CharBufferA and CharBufferB, generate template in ModelBuffer
8	StoreTemplet	07H	Store files in ModelBuffer to flash fingerprint database
9	LoadTemplet	08H	Read a template to ModelBuffer from flash fingerprint database
10	UpTemplet	09H	Upload files in characteristic buffer to HOST
11	DownTemplet	0AH	Download a characteristic file from HOST to characteristic buffer
12	UpImage	0BH	Upload images
13	DownImage	0CH	Download images
14	DeletOneTemplet	0DH	Delete a characteristic file in flash fingerprint database
15	EraseAllTemplet	0EH	Empty flash fingerprint database
16	ReadParTablel	0FH	Read Parameter List
17	SetSecurLecel	12H	<i>Set secure levels</i>
18	SetPwd	13H	Set handshaking password
19	VfyPwd	14H	<i>Verify handshaking password</i>
20	Reset	15H	System reset and go to initial status when power on
21	FlashLED	16H	<i>Light flash indication</i>
22	WriteNotepad	23H	Write notepad
23	ReadNotepad	24H	<i>Read notepad</i>
24	LevelSearch	25H	Conduct level search
25	CheckTemplet	28H	<i>Search fingerprint database</i>

4.2 Confirm Code Definition

No.	Confirm Code	Definition
1	00h	Command execution finished or OK;
2	01h	Packet receive error;
3	02h	No finger on sensor;
4	03h	Fingerprint image enrollment failure;
5	04h	Finger too dry or fingerprint too light and minutiae fail to be generated;
6	05h	Finger too wet or fingerprint unclear and minutiae fail to be generated;
7	06h	Fingerprint in great disorder and minutiae fail to be generated;
8	07h	Fingerprint image is normal, but minutiae are too few to be generated;
9	15H	There is no valid original image files in Buffer to generate fingerprint image;
10	08h	Fingerprints do not match;
11	09h	No fingerprint found;
12	0ah	Minutiae merge failure;
13	0bh	When store templates into database, address ID number is out of fingerprint database range;
14	0ch	Read templates from fingerprint database error;
15	0dh	Minutiae upload failure;
16	0eh	Module fails to receive subsequent data packets;
17	0fh	Image upload failure;
18	10h	Template deletion failure;

19	11h	Empty fingerprint database failure;
20	12h	Fail to sleep;
21	13h	Incorrect Password;
22	14h	System reset failure;
23	15h	Invalid fingerprint data in the current image buffer;
24	16h	Online upgrade failure;
25	17h	There is fingerprint remaining on sensor or pressing finger on sensor for too long;
26	18h	Operate FLASH error
27	19h	No valid templates in the designated position
26	1ah—ffh	Reserved.

4.3 Command in Detail

4.3.1 Detect Finger

- | Command: DetectFinger
- | Function: Detect fingers on sensor
- | Input Parameter: None
- | Return Parameter: Confirm bit
- | Command Code: 01H
- | Command Packet Format:

1 byte	4 bytes	2 bytes	1 byte	2 bytes
Packet Flag	Module Address	Packet Length	Command Code	Check Sum
01H	00H x 4	0001H	01H	0003H

Note: Module Address default value 0

- | Response Packet Format:

1 byte	4 bytes	2 bytes	1 byte	2 bytes
Packet Flag	Resvd	Packet Length	Confirm Code	Check Sum
07H	00H x 4	0001H	xxH	sum

Note: Confirm Code=00H Finger detected;
 Confirm Code=01H Packet receive error;
 Confirm Code=02H No finger detected;
 Sum means Check Sum

4.3.2. Enroll Image

- | Command: GetImage
- | Function: Enroll image from sensor and store the image into ImageBuffer. Return 5 parameters including fingerprint valid area percentage, up/down/left & right border, etc.
- | Input Parameter: none
- | Return Parameter: Confirm bit, valid area (percentage) and up/down/left/right border.
- | Command Code: 02H
- | Command Packet Format:

1 byte	4 bytes	2 bytes	1 byte	2 bytes
Packet Flag	Module Address	Packet Length	Command Code	Check Sum
01H	00H x 4	0001H	02H	0004H

Note: Module Address default value is 0

- | Response Packet Format:

1 byte	4 bytes	2 bytes	1 byte	1byte	1byte	1 byte	1 byte	1 byte	2 bytes
Packet Flag	Resvd	Packet Length	Confirm Code	Area	Up Border	Down Border	Left Border	Right Border	Check Sum
07H	00H x 4	06H	xxH	ValidArea	TB	BB	LB	RB	sum

Note: Confirm Code=00H Enrollment successful;
 Confirm Code=01H Receive packet error;
 Confirm Code=03H Enrollment failure;
 Sum means Check Sum

4.3.3 Generate Minutiae

- I Command: GenTemplet
- I Function:
Generate minutiae as defined in system Configuration List. Fingerprint characteristic file, generated from images in ImageBuffer, is stored in CharBufferA or CharBufferB.
- I Input Parameter: BufferID(Minutiae buffer No.)
- I Return Parameter: Confirm code
- I Command Code : 03H
- I Command Packet Format:

1 byte	4 bytes	2 bytes	1 byte	1 byte	2 bytes
Packet Flag	Module Address	Packet Length	Command Code	Buffer ID	Check Sum
01H	00H x 4	0002H	03H	BufferID	sum

Note: Module Address default value is 0. After the instruction is executed, the image buffer will be **covered**.

- I Response Packet Format:

1 byte	4 bytes	2 bytes	1 byte	2 bytes
Packet Flag	Resvd	Packet Length	Confirm Code	Check Sum
07H	00H x 4	0001H	xxH	sum

Note:

- Confirm Code=00H Generate minutiae successful;
- Confirm Code=01H Packet receive error;
- Confirm Code=04H Fail to generate minutiae because finger is too dry or fingerprint image too light
- Confirm Code=05H Fail to generate minutiae because finger is too wet or fingerprint too ambiguous;
- Confirm Code=06H Fail to generate minutiae because fingerprint image is too random;
- Confirm Code=07H Fingerprint image normal, but minutiae points too few to generate minutiae;
- Confirm Code=15H Fail to generate minutiae because there is no valid images in the buffer.

Sum means Check Sum

4.3.4 Move Minutiae Files

- | Command: MoveTemplet
- | Function: Move characteristic file from one buffer to another
- | Input Parameter: SrcBufferID(source buffer ID), DstBufferID(Destination Buffer ID)
- | Output Parameter: Confirm Bit
- | Command Code: 20H
- | Command Packet Format:

1 byte	4 bytes	2 bytes	1 byte	1 byte	1 byte	2 bytes
Packet Flag	Module Address	Packet Length	Command Code	Buffer ID	Buffer ID	Check Sum
01H	00H x 4	0003H	20H	SrcBufferID	DstBufferID	sum

Note: Module Address default value is 0; CharBufferA , CharBufferB and ModelBuffer codes are 1h, 2h and 3h respectively..

- | Response Packet Format:

1 byte	4 bytes	2 bytes	1 byte	2 bytes
Packet Flag	Resvd	Packet Length	Confirm Code	Check Sum
07H	00H x 4	0001H	xxH	sum

Note: Confirm Code=00H Move successful;
 Confirm Code=01H Packet receive error;
 Sum means Check Sum

4.3.5 Accurate Verification of Two Fingerprint Minutiae

- | Command: MatchTwoTemplet
- | Function: Accurate verification of files from CharBufferA and CharBufferB
- | Input Parameter: None
- | Return Parameter: Confirm Bit
- | Command Code: 04H
- | Command Packet Format:

1 byte	4 bytes	2 bytes	1 byte	2 bytes
Packet Flag	Module Address	Packet Length	Command Code	Check Sum
01H	00H x 4	0001H	04H	0006H

Note:Module Address default value is 0

I Response Packet Format:

1 byte	4 bytes	2 bytes	1 byte	2 bytes	2 bytes
Packet Flag	Resvd	Packet Length	Confirm Code	Scores	Check Sum
07H	00H x 4	0001H	XxH	xxH	sum

Note: Confirm Code=00H Fingerprint matches;
 Confirm Code=01H Packet receive error;
 Confirm Code=08H Fingerprint does not match;
 Sum means Check Sum

4.3.6 Search Fingerprint

- I Command:** Search
- I Function:** Search the whole or part of fingerprint database based on files from CharBufferA or CharBufferB. If the right fingerprint is found, return page number and user info.
- I Input Parameter:** BufferID, StartPage(start page), PageNum (Page Number)
- I Return Parameter:** Confirm Bit, Page Number (of the matched fingerprint template) and user information (32 bytes)
- I Command Code:** 05H
- I Command Packet Format:**

1 byte	4 bytes	2 bytes	1 byte	1 byte	2 bytes	2 bytes	2 bytes
Packet Flag	Module Address	Packet Length	Command Code	Buffer ID	Parameter	Parameter	Check Sum
01H	00H x 4	0006H	05H	Buffer ID	StartPage	PageNum	sum

Note: Module Address default value is 0
 Note: Module Address default value is 0; CharBufferA, CharBufferB and ModelBuffer code are 1h, 2h and 3h respectively.

I Response Packet Format:

1 byte	4 bytes	2 bytes	1 byte	2 bytes	32 bytes	2 bytes
Packet Flag	Resvd	Packet Length	Confirm Code	Page Number	User Info	Check Sum
07H	00H x 4	0023H	xxH	PageID	UserInfo	sum

Note: Confirm Code=00H Fingerprint found;
 Confirm Code=01H Packet receive error;

Confirm Code=09H Fingerprint not found. Page number and user info indicates “0”.

Sum means Check Sum

*The function to write user information reserved for the moment.

4.3.7 Merge Minutiae (Generate Template)

- I Command: MergeTwoTemplate
- I Function: Merge the files from CharBufferA and CharBufferB to generate template; store the results in ModelBuffer.
- I Input Parameter: None
- I Return Parameter: Confirm Bit
- I Command Code: 06H
- I Command Packet Format:

1 byte	4 bytes	2 bytes	1 byte	2 bytes
Packet Flag	Module Address	Packet Length	Command Code	Check Sum
01H	00H x 4	0001H	06H	0008H

Note: Module Address default value is 0.

- I Response Packet Format:

1 byte	4 bytes	2 bytes	1 byte	2 bytes
Packet Flag	Resvd	Packet Length	Confirm Code	Check Sum
07H	00H x 4	0001H	xxH	sum

Note: Confirm Code=00H Merge successful;
 Confirm Code=01H Packet receive error;
 Confirm Code=0aH Fail to merge (two fingerprints are not taken from the same finger);
 Sum means Check Sum

4.3.8 Store Template

- I Command: StoreTemplet
- I Function: Save the template file in ModelBuffer to flash database with designated PageID number
- I Input Parameter: BufferID(Buffer ID), PageID (Fingerprint Database Template ID)

- | Return Parameter: Confirm Bit
- | Command Code: 07H
- | Command Packet Format:

1 byte	4 bytes	2 bytes	1 byte	1 byte	2 bytes	2 bytes
Packet Flag	Module Address	Packet Length	Command Code	Buffer ID	Page Number	Check Sum
01H	00H x 4	0004H	07H	BufferID	PageID	sum

Note: Module Address default value is 0; CharBufferA, CharBufferB and ModelBuffer codes are 1h, 2h and 3h respectively.

Response Packet Format:

1 byte	4 bytes	2 bytes	1 byte	2 bytes
Packet Flag	Resvd	Packet Length	Confirm Code	Check Sum
07H	00H x 4	0001H	xxH	sum

Note: Confirm Code=00H Storage successful;
 Confirm Code=01H Packet receive error;
 Confirm Code=0bH PageID exceeds fingerprint database range;
 Sum means Check Sum

4.3.9 Read Template

- | Command: LoadTemplet
- | Function:
 Read fingerprint template with designated ID number in flash database to Template ModelBuffer
- | Input Parameter: PageID(Fingerprint Database Template ID)
- | Return Parameter: Confirm Bit
- | Command Code: 08H
- | Command Packet Format:

1 byte	4 bytes	2 bytes	1 byte	2 bytes	2 bytes
Packet Flag	Module Address	Packet Length	Command Code	Page Number	Check Sum
01H	00H x 4	0003H	08H	PageID	sum

Note: Module Address default value is 0; CharBufferA, CharBufferB and ModelBuffer codes are 1h, 2h and 3h respectively.

- | Response Packet Format:

1 byte	4 bytes	2 bytes	1 byte	2 bytes
Packet Flag	Resvd	Packet Length	Confirm Code	Check Sum
07H	00H x 4	0001H	XxH	sum

Note: Confirm Code=00H Read successful;
 Confirm Code=01H Packet receive error;
 Confirm Code=0cH Read failure;
 Sum means Check Sum

4.3.10 Upload Minutiae or Template

- l Command: UpTemplet
- l Function: Upload characteristic files in buffer to HOST
- l Input Parameter: BufferID(Buffer ID)
- l Return Parameter: Confirm Bit
- l Command Code: 09H
- l Command Packet Format:

1 byte	4 bytes	2 bytes	1 byte	1 byte	2 bytes
Packet Flag	Module Address	Packet Length	Command Code	Buffer ID	Check Sum
01H	00H x 4	0002H	09H	BufferID	sum

Note: Module Address default value is 0; CharBufferA, CharBufferB and ModelBuffer codes are 1h, 2h and 3h respectively.

- l Response Packet Format:

1 byte	4 bytes	2 bytes	1 byte	2 bytes
Packet Flag	Resvd	Packet Length	Confirm Code	Check Sum
07H	00H x 4	0001H	xxH	sum

Note: Confirm Code=00H Send packet later;
 Confirm Code=01H Packet receive error;
 Confirm Code=0dH Command execution failure;
 Sum means Check Sum

- l Send subsequent packet after reception of response(please refer to 3.1 for packet format)

4.3.11 Download Minutiae or Template

- | Command: DownTemplet
- | Function: HOST download characteristic file to the buffer in module
- | Input Parameter: BufferID (Buffer ID)
- | Return Parameter: Confirm Bit
- | Command Code: 0aH
- | Command Packet Format:

1 byte	4 bytes	2 bytes	1 byte	1 byte	2 bytes
Packet Flag	Module Address	Packet Length	Command Code	Buffer ID	Check Sum
01H	00H x 4	0002H	0aH	BufferID	sum

Note: Module Address default value is 0; CharBufferA, CharBufferB and ModelBuffer codes are 1h, 2h and 3h respectively.

- | Response Packet Format:

1 byte	4 bytes	2 bytes	1 byte	2 bytes
Packet Flag	Resvd	Packet Length	Confirm Code	Check Sum
07H	00H x 4	0001H	xxH	sum

Note: Confirm Code=00H Ready to receive subsequent packets;
 Confirm Code=01H Packet receive error;
 Confirm Code=0eH Unable to receive subsequent packets;
 Sum means Check Sum

- | Receive subsequent data packets after reception of response (please refer to 3.1 for packet format).

4.3.12. Upload Image

- | Command: UpImage
- | Function: Upload data in image buffer to HOST
- | Input Parameter: none
- | Return Parameter: Confirm Bit
- | Command Code: 0bH
- | Command Packet Format:

1 byte	4 bytes	2 bytes	1 byte	2 bytes
Packet Flag	Module Address	Packet Length	Command Code	Check Sum
01H	00H x 4	0001H	0bH	000dH

Note: Module Address default value is 0

I Response Packet Format:

1 byte	4 bytes	2 bytes	1 byte	2 bytes
Packet Flag	Resvd	Packet Length	Confirm Code	Check Sum
07H	00H x 4	0001H	xxH	sum

Note: Confirm Code=00H Continue to send subsequent data packets;
 Confirm Code=01H Packet receive error;
 Confirm Code=0fH Unable to send subsequent data packets;
 Sum means Check Sum

- I Send subsequent data packet after reception of data packet (please refer to 3.1 for data packet format).
- I One byte includes 2 pixels, each occupying 4 bits.

4.3.13 Download Image

- I Command: DownImage
- I Function: HOST download image data to Module
- I Input Parameter: None
- I Return Parameter: Confirm Bit
- I Command Code: 0cH
- I Command Packet Format:

1 byte	4 bytes	2 bytes	1 byte	2 bytes
Packet Flag	Module Address	Packet Length	Command Code	Check Sum
01H	00H x 4	0001H	0cH	000eH

Note: Module Address default value is 0

I Response Packet Format:

1 byte	4 bytes	2 bytes	1 byte	2 bytes
Packet Flag	Resvd	Packet Length	Confirm Code	Check Sum
07H	00H x 4	0001H	xxH	sum

Note: Confirm Code=00H Ready to receive subsequent packets;
 Confirm Code=01H Packet receive error;
 Confirm Code=0eH Unable to receive subsequent packets;

Sum means Check Sum

- | Receive subsequent data packets after reception of response. Data Packet Length must be 128 (please refer to 3.1 for data packet format).
- | One byte includes 2 pixels, each occupying 4 bits.

4.3.14 Delete a Template

- | Command: DeletOneTemplet
- | Function: Delete template with designated ID number in flash database
- | Input Parameter: PageID(Fingerprint database template number)
- | Return Parameter: Confirm Bit
- | Command Code: 0dH
- | Command Packet Format:

1 byte	4 bytes	2 bytes	1 byte	2 bytes	2 bytes
Packet Flag	Module Address	Packet Length	Command Code	Page Number	Check Sum
01H	00H x 4	0003H	0dH	PageID	sum

Note: Module Address default value is 0

- | Response Packet Format:

1 byte	4 bytes	2 bytes	1 byte	2 bytes
Packet Flag	Resvd	Packet Length	Confirm Code	Check Sum
07H	00H x 4	0001H	xxH	sum

Note: Confirm Code=00H Delete template successful;
 Confirm Code=01H Packet receive error;
 Confirm Code=10H Fail to delete template;
 Sum means Check Sum

4.3.15 Empty Fingerprint Database

- | Command: EraseAllTemplet
- | Function: Delete all fingerprint templates in flash database
- | Input Parameter: None
- | Return Parameter: Confirm Bit
- | Command Code: 0eH
- | Command Packet Format:

1 byte	4 bytes	2 bytes	1 byte	2 bytes
Packet	Module	Packet	Command	Check

Flag	Address	Length	Code	Sum
01H	00H x 4	0001H	0eH	0010H

Note: Module Address default value is 0

I Response Packet Format

1 byte	4 bytes	2 bytes	1 byte	2 bytes
Packet Flag	Resvd	Packet Length	Confirm Code	Check Sum
07H	00H x 4	0001H	xxH	sum

Note: Confirm Code=00H Empty successful;
 Confirm Code=01H Packet receive error;
 Confirm Code=11H Empty failure;
 Sum means Check Sum

4.3.16 Read System Parameter List

- I Command: ReadParTable
- I Function: Read module Parameter List
- I Parameter List Format:

1byte	SSR
1byte	OSR
1byte	ESR
2bytes	Resvd
4bytes	Equipment address
8bytes	Configuration list
8bytes	Module No.
8bytes	Software version No.
8bytes	Manufacturer
9bytes	resv

- I Input Parameter: None
- I Return Parameter: Confirm Bit + Parameter List
- I Command Code: 0fH
- I Command Packet Format:

1 byte	4 bytes	2 bytes	1 byte	2 bytes
Packet Flag	Module Address	Packet Length	Command Code	Check Sum

01H	00H x 4	0001H	0fH	0011H
-----	---------	-------	-----	-------

Note: Module Address default value is 0

I Response Packet Format:

1 byte	4 bytes	2 bytes	1 byte	50 bytes	2 bytes
Packet Flag	Resvd	Packet Length	Confirm Code	Parameter List	Check Sum
07H	00H x 4	1+50	xxH	见 Parameter List Format	sum

Note: Confirm Code=00H OK;
 Confirm Code=01H Packet receive error;
 Sum means Check Sum

4.3.17 Set Security Level

I Command: SetSecurLevel

I Function:

Set security level during fingerprint verification.

I Input Parameter: SecurLevel: 1-5

I Return Parameter: Confirm Bit

I Command Code: 12H

I Command Packet Format:

1 byte	4 bytes	2 bytes	1 byte	1 byte	2 bytes
Packet Flag	Module Address	Packet Length	Command Code	Security Level	Check Sum
01H	00H x 4	0002H	12H	1-5	sum

Note: Module Address default value is 0. In the Security Level 5, Module has the lowest FAR and highest FRR. Default security level is 3.

I Response Packet Format:

1 byte	4 bytes	2 bytes	1 byte	2 bytes
Packet Flag	Resvd	Packet Length	Confirm Code	Check Sum
07H	00H x 4	0001H	xxH	sum

Note: Confirm Code=00H OK;
 Confirm Code=01H Packet receive error;
 Sum means Check Sum

4.3.18 Set Password

- | Command: SetPwd
- | Function: Set module handshaking password
- | Input Parameter: PassWord
- | Return Parameter: Confirm Bit
- | Command Code: 13H
- | Command Packet Format:

1 byte	4 bytes	2 bytes	1 byte	4 bytes	2 bytes
Packet Flag	Module Address	Packet Length	Command Code	Password	Check Sum
01H	00H x 4	0005H	13H	PassWord	sum

Note: Module Address default value is 0. After password setting, each time when powered on, system password must be verified first. If user forgets the password, the Module will not work.

- | Response Packet Format:

1 byte	4 bytes	2 bytes	1 byte	2 bytes
Packet Flag	Resvd	Packet Length	Confirm Code	Check Sum
07H	00H x 4	0001H	xxH	sum

Note: Confirm Code=00H OK;
 Confirm Code=01H Packet receive error;
 Confirm Code=12H Unable to sleep;
 Sum means Check Sum

4.3.19 Verify Password

- | Command: VfyPwd
- | Function: Verify module handshaking password
- | Input Parameter: PassWord
- | Return Parameter: Confirm Bit
- | Command Code: 14H
- | Command Packet Format:

1 byte	4 bytes	2 bytes	1 byte	4 bytes	2 bytes
Packet Flag	Module Address	Packet Length	Command Code	Password	Check Sum
01H	00H x 4	0005H	14H	PassWord	sum

Note: Module Address default value is 0

I Response Packet Format:

1 byte	4 bytes	2 bytes	1 byte	2 bytes
Packet Flag	Resvd	Packet Length	Confirm Code	Check Sum
07H	00H x 4	0001H	xxH	sum

Note: Confirm Code=00H Correct password;
 Confirm Code=01H Packet receive error;
 Confirm Code=13H Incorrect password;
 Sum means Check Sum

4.3.20 System Reset

I Command: Reset

I Function: Module soft reset and start system initialization. HOST will wait at least 100ms before sending any instruction packets. In the meanwhile, system handshaking password must be verified.

I Input Parameter: None

I Return Parameter: Confirm Bit

I Command Code: 15H

I Command Packet Format:

1 byte	4 bytes	2 bytes	1 byte	2 bytes
Packet Flag	Module Address	Packet Length	Command Code	Check Sum
01H	00H x 4	0001H	15H	0017H

Note: Module Address default value is 0

I Response Packet Format:

1 byte	4 bytes	2 bytes	1 byte	2 bytes
Packet Flag	Resvd	Packet Length	Confirm Code	Check Sum
07H	00H x 4	0001H	xxH	sum

Note: Confirm Code=00H Reset successful;
 Confirm Code=01H Packet receive error;
 Confirm Code=14H Reset failing;
 Sum means Check Sum

4.3.21 Light Flash Indication

- l Command: FlashLED
- l Function: Instruct Module to flash lights as per request
- l Input Parameter: LEDcode

LEDcode	LED Flash Mode
01h	Red light flashes once
02h	Red light flashes twice
03h	Red light flashes three times
04h	Red light flashes four times
11h	Green light flashes once
12h	Green light flashes twice
13h	Green light flashes three times
14h	Green light flashes four times
20h	Login successful (red light and green light alternatively flash three times)
30h	Login failure indication (red & green light simultaneously flash three times)
40h	Red light and green light following flashes rapidly once
50h	Database full
60h	Time out

n LEDtime

LEDtime	LED Time
1h	50ms
2h	100ms
3h	150ms
4h	200ms
5h	250ms
6h	300ms
7h	350ms

- l Return Parameter: Confirm Bit
- l Command Code: 16H
- l Command Packet Format:

1 byte	4 bytes	2 bytes	1 byte	1 byte	1 byte	2 bytes
--------	---------	---------	--------	--------	--------	---------

Packet Flag	Module Address	Packet Length	Command Code	LED code	LED time	Check Sum
01H	00H x 4	0003H	16H	LEDcode	LEDtime	sum

Note: Module Address default value is 0

I Response Packet Format:

1 byte	4 bytes	2 bytes	1 byte	2 bytes
Packet Flag	Resvd	Packet Length	Confirm Code	Check Sum
07H	00H x 4	0001H	xxH	sum

Note: Confirm Code=00H OK;
 Confirm Code=01H Packet receive error;
 Sum means Check Sum

4.3.22 Write Notepad

I Function: There is a 32-byte FLASH space designated for user to store user data. This command is used to write 32 bytes user data.

I Input Parameter: user content

I Return Parameter: Confirm Bit

I Command Code: 23H

I Command Packet Format:

1 byte	4 bytes	2 bytes	1 byte	32 bytes	2 bytes
Packet Flag	Module Address	Packet Length	Command Code	Notepad Information	Check Sum
01H	00H x 4	0021H	23H	content	sum

Note: Module Address default value is 0

I Response Packet Format:

1 byte	4 bytes	2 bytes	1 byte	2 bytes
Packet Flag	Resvd	Packet Length	Confirm Code	Check Sum
07H	00H x 4	0001H	xxH	sum

Note: Confirm Code=00H OK;
 Confirm Code=01 Packet receive error;
 Sum means Check Sum

4.3.23 Read Notepad

- | Function: Read the 32bytes user data in the FLASH
- | Input Parameter: None
- | Return Parameter: Confirm Bit+ Notepad information
- | Command Code: 24H
- | Command Packet Format:

1 byte	4 bytes	2 bytes	1 byte	2 bytes
Packet Flag	Module Address	Packet Length	Command Code	Check Sum
01H	00H x 4	0001H	24H	0026H

Note: Module Address default value is 0

- | Response Packet Format:

1 byte	4 bytes	2 bytes	1 byte	32 bytes	2 bytes
Packet Flag	Resvd	Packet Length	Confirm Bit	Notepad Information	Check Sum
07H	00H x 4	1+32	xxH	User content	sum

Note: Confirm Code=00H OK;
 Confirm Code=01H Packet receive error;
 Sum means Check Sum

4.3.24 Level Search Fingerprint Database

According to the FLASH capacity, fingerprint database is divided into 3 levels (240, 752 & 1776), defined as LEVEL1, LEVEL2 and LEVEL3 accordingly (Priority level from high to low). LEVEL1 ranges from 0 to 239; LEVEL2 ranges from 240-751; LEVEL3 ranges from 752-1775. When searching the whole database, the first goes to LEVEL1. If the right fingerprint file is found, then send back fingerprint ID and user info; otherwise, keep working to other levels of database. If no corresponding fingerprint is found in all three databases, the system will return info “no target fingerprint is found”.

- | Command: LevelSearch
- | Function: Level search the whole database according to the minutiae files in CharBufferA or CharBufferB. If fingerprint is found, then return Buffer ID & user info.
- | Input Parameter: BufferID
- | Return Parameter: Confirm Bit, fingerprint database template ID(matched fingerprint template) and user info(32bytes)

- I Command Code: 25H
- I Command Packet Format:

1 byte	4 bytes	2 bytes	1 byte	1 byte	2 bytes
Packet Flag	Module Address	Packet Length	Command Code	Buffer ID	Check Sum
01H	00H x 4	0002H	25H	BufferID	sum

Note: Module Address default value is 0

Note: Module Address default value is 0. The CharBuffer A & CharBufferB codes are 1h & 2h respectively.

- I Response Packet Format:

1 byte	4 bytes	2 bytes	1 byte	2 bytes	32 bytes	2 bytes
Packet Flag	Resvd	Packet Length	Confirm Code	Page ID	User Info	Check Sum
07H	00H x 4	0023H	xxH	PageID	UserInfo	sum

Note: Confirm Code=00H Fingerprint found;
 Confirm Code=01H Packet receive error;
 Confirm Code=09H No fingerprint found, BufferID and User Info are both 0.
 Sum means Check Sum

4.3.25 Check Fingerprint Database

- I Command: CheckTemplet
- I Function: Check if there is valid template within the designated page ID in the fingerprint database.
- I Input Parameter: PageID
- I Return Parameter: Confirm Bit
- I Command Code: 28H
- I Command Packet Format:

1 byte	4 bytes	2 bytes	1 byte	2 bytes	2 bytes
Packet Flag	Module Address	Packet Length	Command Code	Page ID	Check Sum
01H	00H x 4	0003H	28H	PageID	0026H

Note: Module Address default value is 0

- I Response Packet Format:

1 byte	4 bytes	2 bytes	1 byte	2 bytes
Packet Flag	Resvd	Packet Length	Confirm Code	Check Sum
07H	00H x 4	0001H	xxH	sum

Note: Confirm Code=00H There is valid template within the designated page ID;

Confirm Code=19H There is no valid template within the designated page ID;

Confirm Code=01H Packet receive error

Sum means Check Sum

Attachment I Methods to Lower FRR

- 1) After template enrollment, verify the fingerprint again. If it is verified, the template is valid and reserve the template for future use; If fail to verified, template is invalid and should enroll again.
- 2) One single finger can enroll in several templates;
- 3) Thumb, index finger and middle finger are highly recommended. The third finger and little finger are not recommended;
- 4) For dry fingers, they shall be pressed heavily; if the finger is sweaty, it shall be dried first, and press lightly.
- 5) Use soft cloth to eliminate the dirt or sweat on the sensor window. Keep the window clean.
- 6) Due to parameter adjustment, time might be some differences in enrolling fingers of different people. For some people, it may take longer; others may take shorter time.
- 7) Avoid direct sunshine when use.